

Thermal Print Heads For Barcode and Label Printers

BHP4223HS

FEATURES

- High-speed type with three-stage LATCH heat history control [HS type]
- New-BP protective layer with excellent abrasion resistance is used.

APPLICATIONS

- Barcode and label printers
- Bank ATMs
- Amusements
- Ticket-vending machines
- POS terminals

PRODUCT SPECIFICATIONS

HEATING ELEMENT SPECIFICATIONS

Number of heating elements	(dots)	448
Dot density	(dots/mm)	8
	(DPI)	203
Length of heating element array (effective)	(mm)	56
Heating element average resistance	(Ω)	800
Glaze type		Partial glaze

DRIVE CONDITIONS

Applied platen diameter	(mm)	$\phi 20$ max.
Paper-feed speed	(mm/sec)	200max.
Data transfer frequency	(MHz)	5max.
Driver power supply	(V)	4.5 to 5.5

SHAPES AND DIMENSIONS

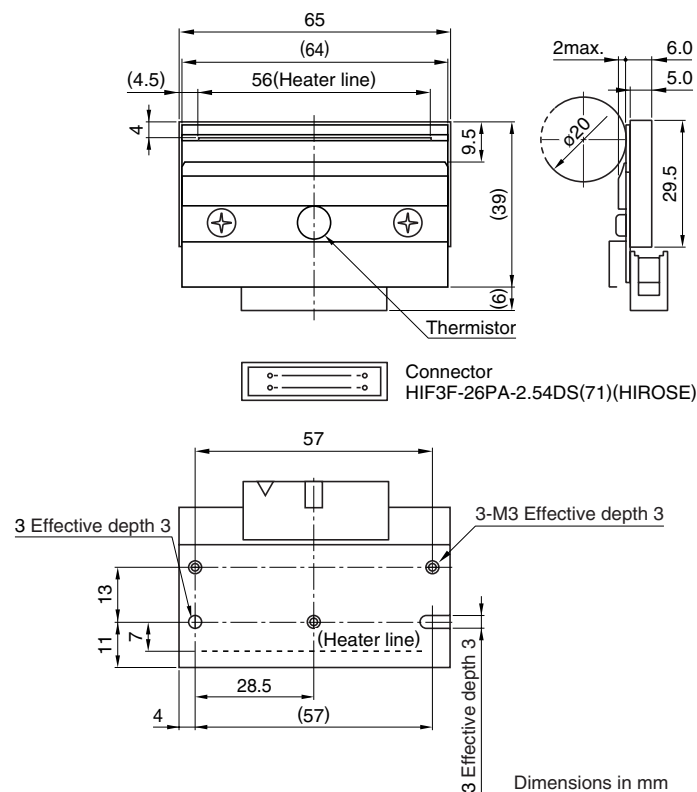

• All specifications are subject to change without notice.